

## Our Commitment

When you see a psychologist you are contracting for a professional service.

### *Confidentiality*

Your information is confidential. It is released only with your written authorization or as required by law. Please advise us of any special confidentiality requirements.

### *Cost*

We follow PAA fee guidelines. Psychological services are covered by employer health benefits, FNIHB (with Treaty Status), some government programs or private insurance.

### *Attendance*

We will see you promptly and will try to accommodate your schedule. We need 24 hours notice to cancel or rebook. An appointment is typically 50 minutes in length.

### *Referrals*

We appreciate your referrals to ARCH. Please discuss with us any questions you may have about how to make an effective referral.

## Administrative Contacts

Please feel free to contact our administrative staff regarding any practical concerns



**Rebecca Lay**  
Office Manager

**Lambert Duque**  
Administrative Assistant



*Where to Find us:*

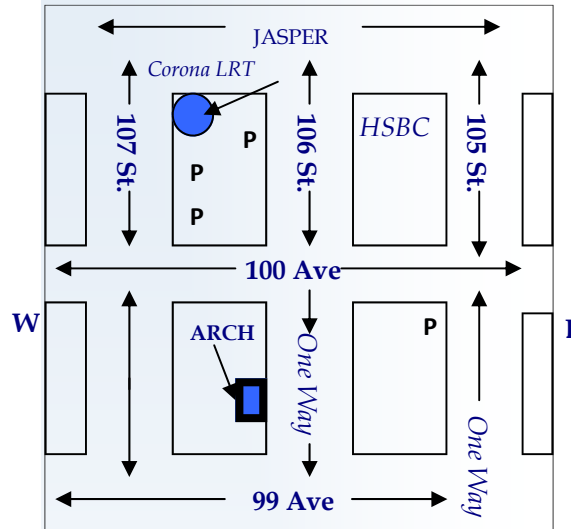

*Parking is available on 106th street and 99th avenue. Daily parking available off 107th Street and 100th Avenue*



ARCH Psychological Services

Suite 39, 9912 - 106 Street Edmonton, AB T5K 1C5

Phone: 780-428-9223 Toll free: 1-855-214-7542

Fax: 780-428-7061

E-mail: arch@archpsychological.com

### **Additional Locations**

Unit A, 4732—53 Ave  
High Prairie, AB

Suite 1106, 13 Mission Ave  
St. Albert, AB

# ARCH

## Psychological Services

**Our People  
Our Services  
Our Commitment**

[www.archpsychological.com](http://www.archpsychological.com)

**Edmonton,  
St. Albert & High Prairie**

**780-428-9223  
1-855-214-7542**

*Times of crisis are  
opportunities for healing,  
change and growth*



## Talk to Someone Who can Help



### **Tanya Spencer, Ph.D., R. Psych.**

- Childhood Disorders
- School/Parent Consultation
- Behavioral Therapies

### **Stasia Lucki, M.Psych., R. Psych.**

- Play Therapy
- E.M.D.R.
- Post-traumatic Stress



### **Amanda Baird, M.A., R. Psych.**

- Forensic Assessments & Therapy
- Psycho Educational Evaluations
- Therapy with Aboriginal Youth

### **Tami Duncan, M.Ed., R. Psych.**

- Sexual Disorders & Addictions
- Individual Therapy for Life Transitions



### **Erin Hawkins, M.Ed., R. Psych.**

- Health & Sports Psychology
- Family Therapy

### **Lisa Rowse, M.A.**

#### **Provisionally Registered Psychologist**

- Children & Families
- Health Psychology



### **Chris Janzen, M.Ed.**

#### **Provisionally Registered Psychologist**

- Psychoeducational assessments
- Child & youth therapy

## We Are Here For You

*As you face challenges:*

- As a victim of trauma e.g. childhood abuse, sexual abuse, a current crisis situation
- As a parent with parenting or custody/access concerns
- When suffering from a health problem
- In facing criminal charges
- In dealing with addictions to substances, pornography or other dysfunctional behaviors
- As an Aboriginal/First Nations individual or family
- In personal wellbeing or in relationships



### **Al Riediger, Ph.D., R. Psych.**

- Personal psychotherapy with a view to healing in depth from past trauma or current crises
- Psycho-legal assessments
- Healing in relationships
- Treatment for sexual victims and offenders

### **George Lucki, M.Phil., R. Psych.**

- Assessment of complex psychological health concerns
- Psycho-legal issues in family law, civil litigation and criminal cases
- Treatment for past trauma, mood, personality and relationships



## Our Services

**Therapy:** For individuals dealing with depression, anxiety, life crises

Relationship **Counseling:** For couples, families, peers

Health **Consultation:** To address physical health issues e.g. stress management, diabetes, self-harm

**Sexual functioning enhancement**

Problem oriented **psychotherapy** for addictions, phobias, P.T.S.D.

Academic/Vocational **Assessments** of learning disabilities, intelligence and vocational interest,

**Clinical Assessment:** Personality, stress, behavioral problems

**Forensic Assessments:** Risk, sexual dysfunction, pre-sentence reports, treatment planning

**Litigation Support:** Custody and Access, Posttraumatic Stress Disorder, parenting evaluations

